

PoE (Power over Ethernet) Dual Voltage Splitter 12Vdc @ 1.75A and PoE @ 25.5 Watt Installation Guide



Purpose of this Guide

This Guide provides information and procedures for the product installation and operation of the PoE ULTRA HIGH POWER Dual Voltage Splitter (LP-4912POE). This document is intended for technical personnel responsible for installing and operating Power over Ethernet products in a Local Area Network (LAN) environment. To use this document effectively, you should have a working knowledge of Local Area Networking (LAN) concepts and hardware installation. In addition, you should be familiar with the following: Connection of Patch Cables with RJ45 connectors and the LAN addressing map for your particular Network, Mounting of Network hardware in a 19" equipment rack and local practices for power cord connections.

IMPORTANT SAFETY INSTRUCTIONS FROM LAN-Power

Read and keep these instructions. Follow all instructions and heed all warnings. Do not use this equipment near water and clean only with a dry cloth. Do not block any equipment ventilation openings. Install in accordance with manufacturer's instructions. Do not install near any heat sources such as radiators, heat registers, stoves, or other apparatus (including amplifiers) that produce heat. Do not defeat the safety purpose of the polarized or grounding-type plug. Unplug this equipment during lightning storms or when unused for long periods of time. Refer all servicing to qualified service personnel. Servicing is required when the equipment has been damaged in any way, such as power cord or plug damaged, liquid has been spilled, or object has fallen into the equipment, the equipment has been exposed to rain or moisture, does not operate normally, or has been dropped. The AC mains outlet, or appliance coupler shall be readily available to the operator as a means of power disconnection.

WARNING - Only connect equipment to mains power outlet having protective earthing or grounding connection. To reduce the risk of fire or electric shock, do not expose this equipment to rain or moisture.

CAUTION - These servicing instructions are for use by qualified service personnel only. To reduce the risk of electric shock, do not perform any servicing other than that contained in the operating instructions unless you are qualified to do so.

If You need Help or additional support relating to the contents of this Guide, please contact LAN Power using one of the following methods: Phone: 1-510-275-4572 Fax: 1-510-824-5654 Mail: LAN Power, 47835 Westinghouse Drive, Fremont, CA 94539 Web Address: www.lan-power.com Email: support@lan-power.com

Before contacting LAN-Power for technical support, please have the following information ready: the product model number and unit serial number. A description of the failure or symptoms of problem. A description of any action(s) already taken to resolve the problem (e.g., changing ports, rebooting the unit, etc...). The type of End device being powered including Manufacturer name and part number. Powering requirements of the End device. A description of your Network environment (layout, Ethernet switch description, cable type, etc...). The unit history (i.e., have you returned the unit before, is this a recurring problem, etc...)



Please note only qualified personnel should install this unit and read instructions before attempting to install this unit



Verifying Contents of Package - Unpack the PoE Dual Voltage Splitter and verify that you have the following item: LP-4912POE Power over Ethernet Dual Voltage Splitter

Technical Considerations - Before you mount the Splitter to a fixed location, consider all of the following: Determine optimal placement, checking all cable paths and routing. Collect and document Network information as required. **Notes:** 1.) The Splitter is not a repeater and does not amplify the Ethernet data signal. Ensure the cable length from the Ethernet Network Switch to the Powered End device does not exceed 328 feet/100 meters total length. 2.) The Splitter must be used in conjunction with a PoE compliant PSE (Power Supply Equipment) such as the **LP-2575 ULTRA HIGH POWER PoE Midspan Injector**. **The PSE must have 12.5k ohm detection and a Minimum Output of 60 Watts** for the LP-4912POE Dual Voltage Splitter to operate.

Powering Up and Installing the Splitter

NOTE: DO NOT apply power to devices until all connections have been terminated properly.

- 1.) Connect the 2 wires (**White** Wire '+' Positive and **Black** Wire '-' Negative) from the top of the LP-4912POE to the appropriate 12Vdc Power Input connections of End Device ensuring correct polarity. Failure to connect the polarity correctly or shorting the 2 wires together while Splitter is powered can and will cause permanent damage to the LP-4912POE Dual Voltage Splitter. The Maximum 12vdc power available is 1.75 Amp.
- 2.) From the End IP Device connect the RJ45 Male Connector to the RJ45 Female Connector on the bottom left of the LP-4912POE Dual Voltage Splitter labeled '**OUT**'. The LP-4912POE will provide up to 25.5 Watts of PoE Power and pass up to 1000Mbs (Gigabit) of data through the Splitter. Note that the Maximum cable distance from the IP End Device to the Ethernet Switch is 100 Meters / 328 Feet.
- 3.) From the PSE (Power Supply Equipment such as PoE Midspan Injector or Endspan PoE Switch) connect the incoming PoE (Power over Ethernet) via RJ45 Male Connector to the RJ45 Female Connector on the bottom right of the LP-4912POE Dual Voltage Splitter labeled '**IN**'.

Note: The PSE must have 12.5kohm detection and a Minimum PoE Output of 60 Watts to operate. Use in conjunction with LP-2575 ULTRA HIGH POWER Midspan Injector.

- 4.) Ensure all connections have been terminated appropriately to all the devices and then apply Mains Power and Power Up the PSE (Power Supply Equipment such as the LP-2575 ULTRA HIGH POWER PoE Midspan Injector). The LP-4912POE will send appropriate Detection Signal/Handshake to the PSE and the PSE will provide PoE power to the LP-4912POE. The **GREEN** status LED (on top left of the LP-4912POE) will illuminate. Once the GREEN status LED is illuminated the LP-4912POE has appropriate incoming power and the output is providing 12Vdc power and PoE Power
- 5.) The LP-4912POE has two mounting tabs (top right and bottom left of the unit) which should be screwed into place to ensure unit is fixed appropriately.

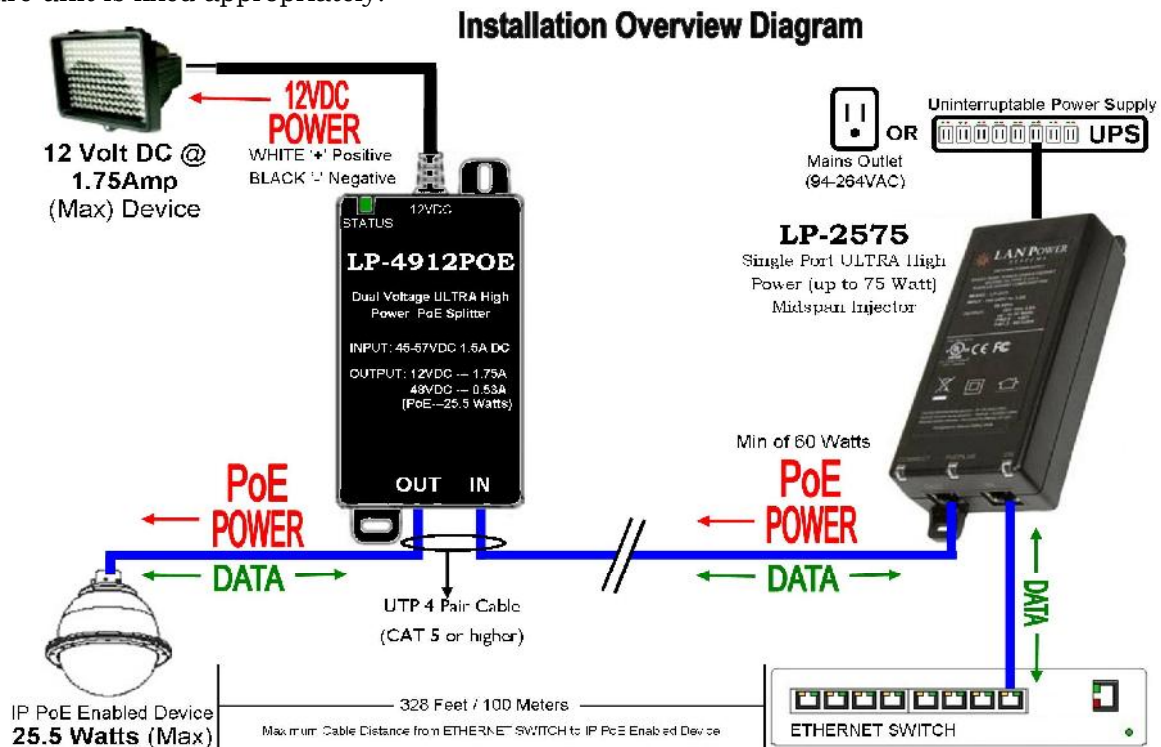

Two Year Limited Warranty

LAN-Power warrants to the original consumer or purchaser that each of its products, and all components thereof, will be free from defects in material and/or workmanship for a period of 2 years from the original purchase date. Any warranty hereunder is extended only to the original consumer or purchaser and is not assignable.

Notice to user

LAN-Power reserves the right to make changes in specifications and other information contained in this document and its web site without prior notice. The reader should in all cases consult LAN-Power to determine whether any such changes have been made. The hardware described in this document is subject to change without notice due to market conditions or user requirements.

SAFETY APPROVAL

This Equipment meets the following safety approval:



 **LAN-POWER**

44240 Fremont Blvd
Fremont, Ca. 94538-6000 USA
Telephone: +1-510-275-4572 FAX: +1-510-284-2420
www.lan-power.com support@lan-power.com